

ALFA

Monolithic Isolation Joints

*Manufactured for Current Pipeline Products™,
a division of IMAC Systems, Inc.*

**For long-term
dependability
experts
choose**

ALFA

**Exceptional isolation
joints for pipeline
projects, welded
into place for a
permanent solution**



**CURRENT
PIPELINE PRODUCTS™**

A division of IMAC Systems, Inc.

www.imacsystems.com

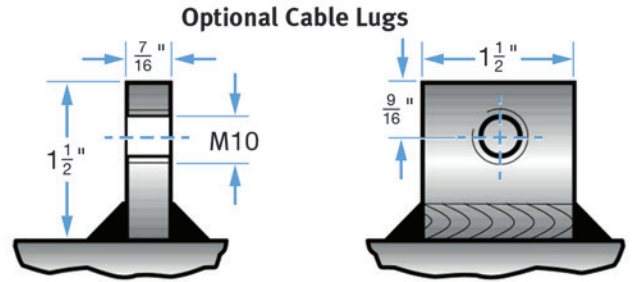
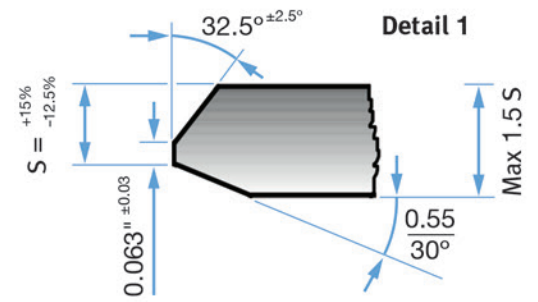
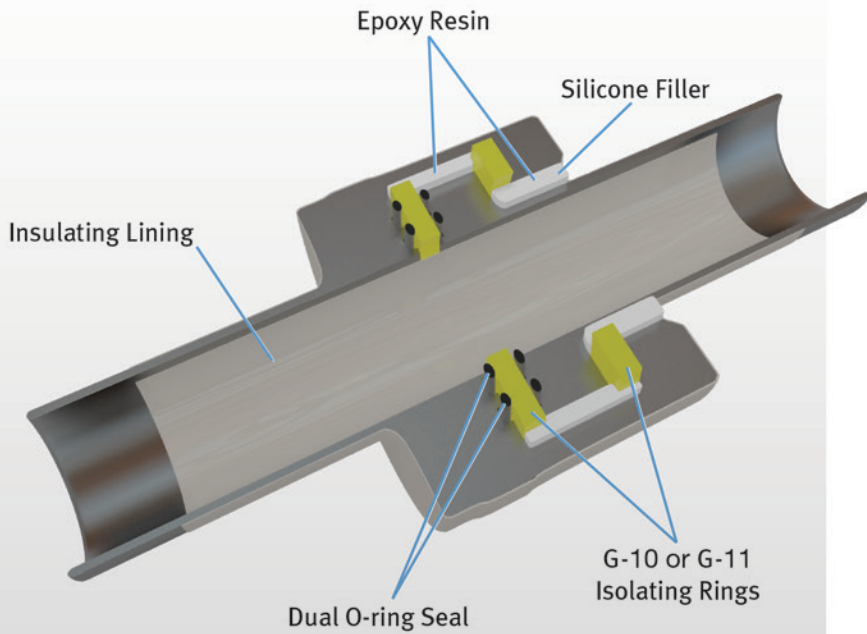

FEATURES

- Industry-proven double O-ring seals standard (available with triple O-ring seals based on application)
- Standard O-ring material 'NBR' (other materials optional based on application)
- O-ring design in accordance with ASTM D2240, ASTM D412, ASTM D395, ASTM D1329, ASTM D1817 and ASME VIII Div. 1 appendix II
- Isolating elements: NEMA G10/G11 – ASTM D709 Class H
- Back seal: silicone neutral low module/filler isolator: epoxy resin cold cured
- Internal and external coating of amine cure epoxy resin
- Pipe pups API 5L x52 or API 5L Grade B (other materials available as per customer requirements)
- Welding in accordance with ASME IX

TESTING

- Dielectric strength test (minimum) 5 kV at 50 hz for 1 minute (dry air)
- Electrical resistance test (minimum) 200 MΩ at 1 kV DC (dry air)
- Hydrostatic test 1.5 times design pressure (1 hour)
- Pneumatic air test
- Hydro-fatigue test: 5 cycles at 80% TP
- NDE pipe bevels and closure weld
MT/UT – ASME V – ASME VIII
- NDE W1 – W2 butt welds
MT/UT/RX – ASME V – ASME VIII
- Further tests available as per customer requirements

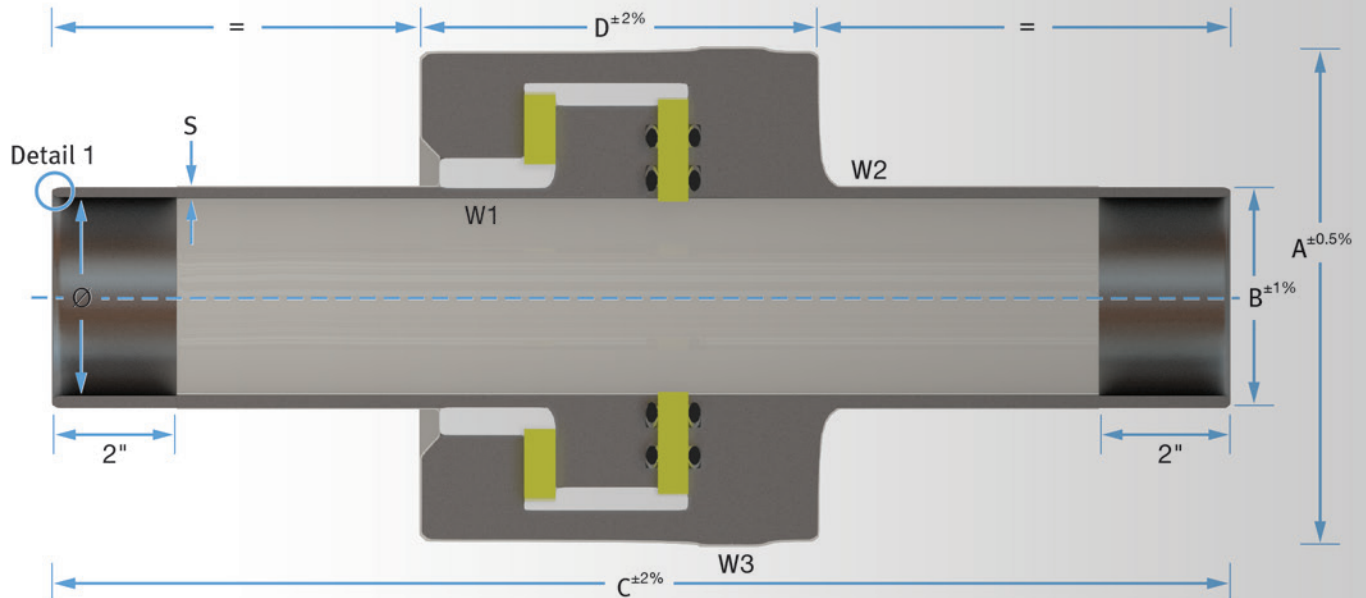

ALFA Monolithic Joint ANSI 150 Class

PIPE Ø (inches)	A (inches)	B (inches)	C (inches)	C (mm)	D (inches)	S (inches)	GRADE	APPROXIMATE WEIGHT (lbs)
½*	3.07	0.84	11.811	300	2.10	0.110	API 5L B	4
¾*	3.46	1.05	11.811	300	2.13	0.113	API 5L B	6
1*	3.70	1.31	11.811	300	2.13	0.133	API 5L B	7
1¼	4.02	1.66	11.811	300	2.60	0.141	API 5L B	9
2	5.12	2.37	27.559	700	3.07	0.154	API 5L B	21
2½	5.28	2.87	27.559	700	3.07	0.203	API 5L B	24
3	6.22	3.50	27.559	700	3.31	0.216	API 5L B	34
4	7.17	4.50	27.559	700	3.54	0.237	API 5L B	45
6	9.69	6.63	27.559	700	4.72	0.280	API 5L X52	88
8	11.42	8.63	27.559	700	4.72	0.322	API 5L X52	113
10	13.62	10.75	27.559	700	5.67	0.365	API 5L X52	165
12	16.22	12.75	39.370	1000	6.61	0.375	API 5L X52	287
14	17.17	14	39.370	1000	6.38	0.375	API 5L X52	293
16	19.21	16	39.370	1000	7.09	0.375	API 5L X52	353
18	21.18	18	39.370	1000	7.56	0.375	API 5L X52	402
20	22.76	20	39.370	1000	8.27	0.375	API 5L X52	441
24	27.01	24	39.370	1000	10.16	0.375	API 5L X52	589
26	29.45	26	39.370	1000	10.39	0.375	API 5L X52	701
28	31.42	28	39.370	1000	10.63	0.375	API 5L X52	758
30	33.31	30	39.370	1000	11.81	0.375	API 5L X52	838
32	35.91	32	39.370	1000	12.68	0.500	API 5L X52	1182
36	40.16	36	47.244	1200	14.57	0.500	API 5L X52	1620
42	45.67	42	47.244	1200	16.54	0.750	API 5L X60	2698

ALFA Monolithic Joint ANSI 300/400 Class

PIPE Ø (inches)	A (inches)	B (inches)	C (inches)	C (mm)	D (inches)	S (inches)	GRADE	APPROXIMATE WEIGHT (lbs)
½	3.15	0.84	11.811	300	2.36	0.110	API 5L B	6
¾	3.46	1.05	11.811	300	2.36	0.113	API 5L B	6
1	3.70	1.31	11.811	300	2.36	0.133	API 5L B	7
1¼	4.02	1.66	11.811	300	2.83	0.141	API 5L B	9
2	5.12	2.37	27.559	700	3.38	0.154	API 5L B	22
2½	5.35	2.87	27.559	700	3.54	0.203	API 5L B	27
3	6.22	3.50	27.559	700	3.54	0.216	API 5L B	35
4	7.16	4.50	27.559	700	4.01	0.237	API 5L B	49
6	9.76	6.63	27.559	700	5.19	0.280	API 5L X52	95
8	11.42	8.63	27.559	700	5.20	0.322	API 5L X52	119
10	13.62	10.75	27.559	700	6.60	0.365	API 5L X52	179
12	16.22	12.75	39.370	1000	7.56	0.375	API 5L X52	304
14	17.17	14	39.370	1000	7.79	0.375	API 5L X52	320
16	19.29	16	39.370	1000	8.50	0.375	API 5L X52	386
18	21.18	18	39.370	1000	9.21	0.375	API 5L X52	441
20	23.23	20	39.370	1000	10.16	0.500	API 5L X52	619
24	27.16	24	39.370	1000	10.63	0.500	API 5L X52	772
26	29.68	26	39.370	1000	12.52	0.500	API 5L X52	926
28	31.89	28	39.370	1000	12.99	0.625	API 5L X52	1202
30	33.78	30	47.244	1200	13.70	0.625	API 5L X52	1448
32	36.53	32	47.244	1200	14.33	0.625	API 5L X52	1682
36	40.55	36	55.118	1400	14.56	0.750	API 5L X52	2288
42	46.06	42	55.118	1400	18.43	0.750	API 5L X52	3075

ALFA Monolithic Joint ANSI 600 Class

PIPE Ø (inches)	A (inches)	B (inches)	C (inches)	C (mm)	D (inches)	S (inches)	GRADE	APPROXIMATE WEIGHT (lbs)
½	3.31	0.84	11.811	300	2.60	0.110	API 5L B	6
¾	3.54	1.05	11.811	300	2.60	0.113	API 5L B	7
1	3.78	1.31	11.811	300	2.83	0.133	API 5L B	9
1¼	4.02	1.66	11.811	300	3.07	0.141	API 5L B	10
2	5.20	2.37	27.559	700	4.33	0.154	API 5L B	26
2½	5.43	2.87	27.559	700	4.25	0.203	API 5L B	30
3	6.22	3.50	27.559	700	4.25	0.216	API 5L B	38
4	7.16	4.50	27.559	700	4.72	0.237	API 5L B	51
6	9.76	6.63	27.559	700	6.37	0.280	API 5L X52	106
8	11.42	8.63	27.559	700	6.85	0.322	API 5L X52	134
10	13.78	10.75	27.559	700	8.27	0.365	API 5L X52	205
12	16.53	12.75	39.370	1000	9.21	0.375	API 5L X52	357
14	17.17	14	39.370	1000	8.03	0.500	API 5L X52	401
16	19.61	16	39.370	1000	11.10	0.500	API 5L X52	538
18	22.05	18	39.370	1000	11.26	0.500	API 5L X52	655
20	23.62	20	39.370	1000	12.05	0.500	API 5L X52	708
24	28.35	24	47.244	1200	14.02	0.625	API 5L X52	1228
26	30.47	26	47.244	1200	15.20	0.625	API 5L X52	1409
28	32.68	28	47.244	1200	15.83	0.625	API 5L X52	1590
30	34.65	30	47.244	1200	16.93	0.625	API 5L X52	1779
32	37.40	32	47.244	1200	18.19	0.750	API 5L X52	2330
36	41.34	36	55.118	1400	18.35	0.750	API 5L X52	2804
42	48.43	42	55.118	1400	23.39	0.790	API 5L X60	4370

*½", ¾" and 1" ANSI 150 joints use a single O-ring design

Sizing charts are not all inclusive. Capacities from ½" diameter to over 120" diameter; ANSI: 150/300/600/900/1500/1500/5000; API: 10,000/15,000 available. Other pipe grades available upon request.

**ALFA
Monolithic
Isolation Joints
serve as a
positive
leak-proof,
long-lasting
block against
the flow of
electric current
in piping
systems**

ABOUT IMAC SYSTEMS, INC.

Manufacturers and distributors of equipment for the mitigation and control of corrosion, specializing in cathodic protection.

Why ALFA Monolithic Insulated Joints?

1. Over 30 years of experience in engineering and manufacturing monolithic joints
2. Factory manufactured and tested, no field assembly required, eliminates short circuits and guarantees performance
3. Mechanical design resists effects of stress and the resulting insulation failure
4. Every joint has stringent quality control
5. Simplified serviceability and maintenance
6. Designed for considerable external loads (bending/torsion/axial) in addition to internal pressure
7. High safety design factor

Additional Options

1. Cable Lugs
2. Weldless pipe pups for special applications
3. Triple O-ring seals (Class API 10,000)
4. Additional O-ring materials
5. Additional testing based on specific requirements
6. Special cryogenic or sour/toxic environment monolithic joints available



® *Manufactured by Alfa Engineering Company Cooperative, an ISO 9001:2008 Registered Manufacturer*

Fully Tested and Ready for Installation



Systems, Inc.

International Measurement and Control Systems

90 Main Street, PO Box 1605 • Tullytown, PA 19007
1-800-955-4GAS • Phone: (215) 946-2200 • Fax: (215) 943-2984
Email: sales@imacsystems.com www.imacsystems.com